



16027 Hwy 64 East – Anamosa, Iowa 52205

Phone: 319-462-2344 or 888-962-2344

Email: [scaletec@scale-tec.com](mailto:scaletec@scale-tec.com)

## Scale System for John Deere 1770 CCS w/ KSI bracket

# Instruction Booklet



This product application is covered by U.S. Patents;

PATENTS: 6,732,667—7,059,258—7,273,017—7,357,087—7,448,335—7,523,710

PATENT PENDING: 12/427,915





1. Using a fork lift, lift the side of the hopper and remove the rear leg. **NOTE: It is easier to work on rear legs with the planter wings folded in.**

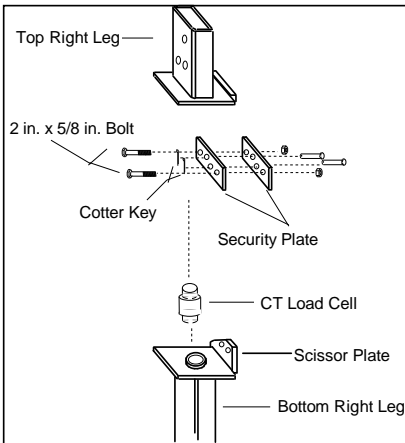

2. Assemble the new legs. Place the CT Load Cell between the top and bottom legs. Use the 5/8" x 2" bolts on the outside two holes of the security plates. On the center holes of the security plates, use the clevis pins to secure the plate. Tighten 5/8 in. bolts until the bolt is snug. Repeat step for other side.



3. Replace the old leg with the new leg assembly. Install the new leg assembly with the scissor plates to the outside of the machine.

After installing the new leg, loosen the lock nut on the bolts that hold the security plates together, so the bolts themselves can be turned by hand.



4. Front Mount Assembly. Remove the bolts to the front load cell bracket and frame. Lift front leg up 3/4 in. and install the weigh bar into the sleeve of the front leg. Use the 3/4 in. x 4 in. bolts.

**NOTE: It is important that the load cell arrow, located on the end of the load cell, must be pointed up.**

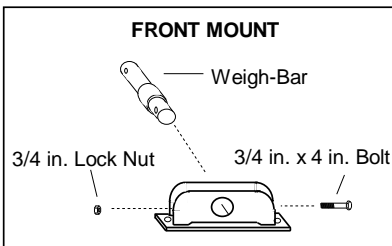

5. Install the Front Mount Bracket by using the 3/4 in. x 4 in. bolts.

Let the hopper down and use the existing bolts to hold the end bracket to the frame. Make sure you have clearance between the main bracket and the frame. The holes are slotted on the end bracket. You may need to adjust the bracket before tightening bolts

### Load Cell Connection:

The indicator is designed to operate with strain gage load cells. The load cells are connected to the terminal board inside the indicator. Remove the four front screws, on the front panel of the indicator, to locate the terminal board. The indicator can be mounted on the railing between the two hoppers. Use parts H151618 and H136110 (two each) and bolt it to the indicator mounting bracket. This will allow you to swivel to the rear while filling and swivel to the front for planting.

### Power Cord:

Red and white wire positive, black wire is negative.

### Cab Mounting:

A junction box can be added to system if cables are too short to reach tractor cab.

If you have any questions regarding the installation or the product, give us a call at (319)-462-2344, or toll free +1-888-962-2344.



Above: the indicator can also be mounted to the railing. It can then be turned to face backward while filling the hoppers, and turned forward for observation from the cab while planting.



# John Deere 1770 CCS Scale System

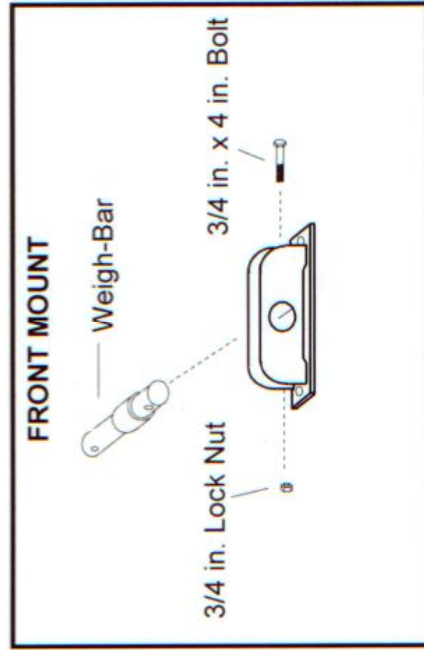
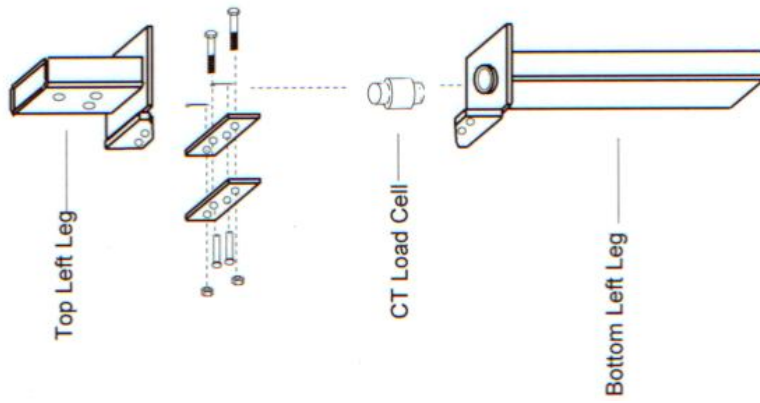
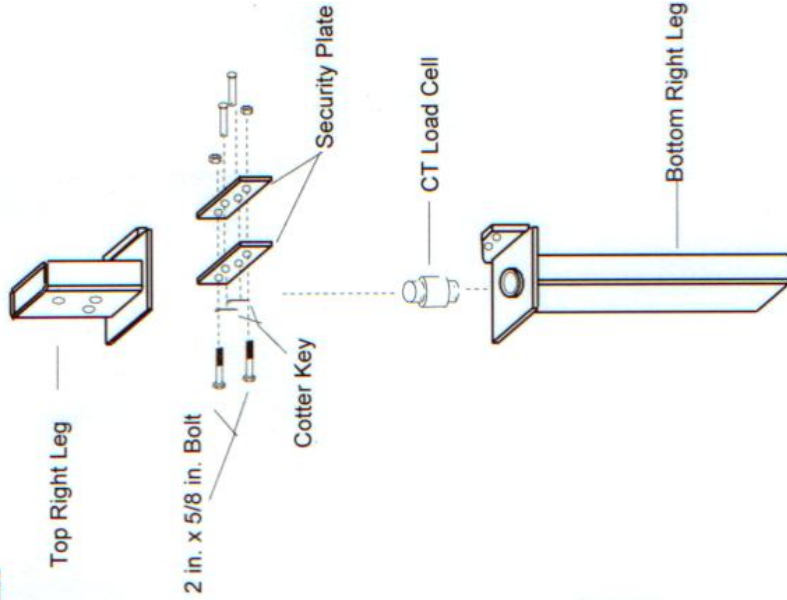

(Patent Pending)

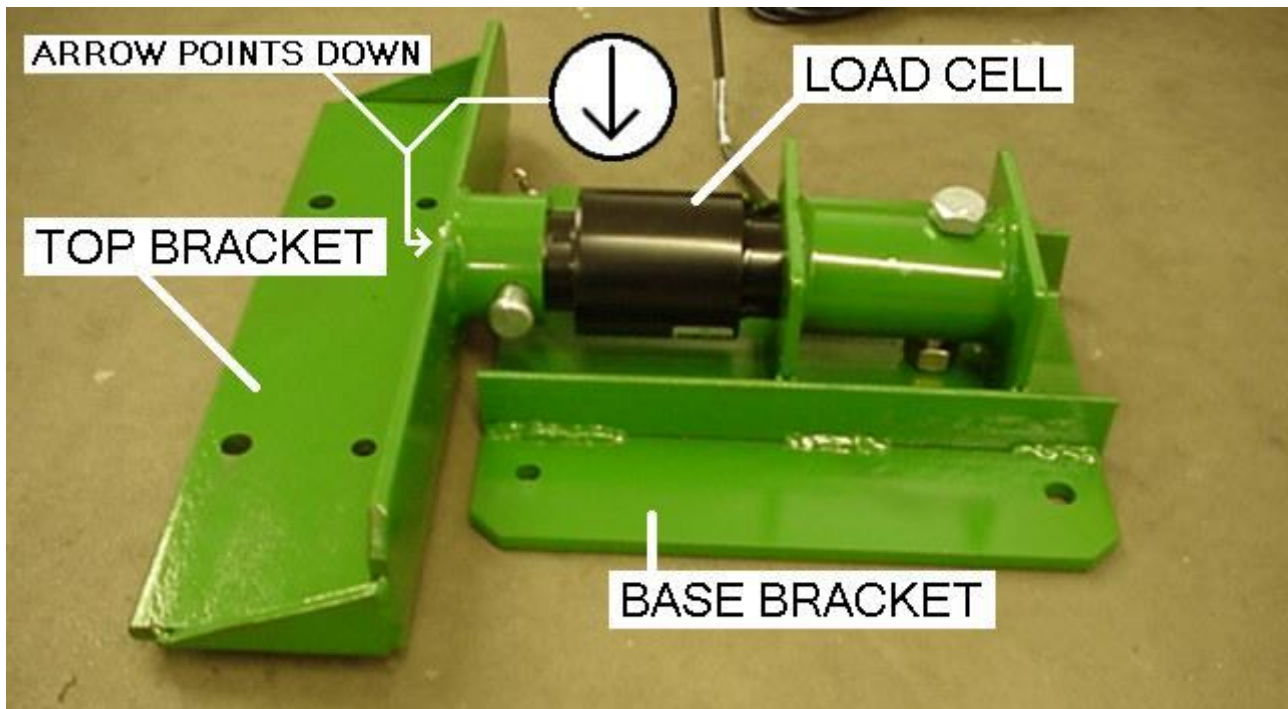

**Lift the KSI bracket & step bracket and then install the TOP BRACKET. Reuse the existing U-bolts to install the BASE BRACKET.**

**Power Connection:**

The power cable should be connected directly to a vehicle battery or regulated power supply. The scale end of the power cable is attached to the J901 connector located on the bottom panel of the scale.

Connect the RED wire from the power cable to +12 VDC and the BLACK wire to GROUND. The indicator is fused internally at 4 amps.

Power Cable Connections:

<b>Wire color</b>	<b>Wire Function</b>
Red	<i>Battery (+12 VDC)</i>
Black	<i>GROUND</i>

**Load Cell Connection:**

The indicator is designed to operate with strain gage load cells. The indicator will normally be supplied with a "J-BOX" cable going between the scale and the load cell junction box. Extension kits are available from your dealer in various lengths.

To connect the load cells, attach the junction box cable to the J902 or J903 connector on the bottom panel of the scale.

## How to use a scale on a Central Fill System

\*\*\* The example we are using is 2000 lbs of seed evenly filled in both hoppers. There is 25 lbs of seed left from the last fill.

1. Push the 'Start' button. The screen will show zero, and the arrow is now pointing to 'Net' on the screen. This is a temporary zero point to start loading the planter with seed. You will now fill 1000 lbs of seed into the left hopper.
2. Push the 'Stop' button, the readout now reads 1025 lbs of seed inventory.
3. Push the 'Start' button again. The screen will say zero again. Load another 1000 lbs of seed into the right side.
4. Now push 'Stop,' and the screen will read 2025 lbs of seed. The numbers will work lower as the seed is planted.