



16027 Hwy 64 East – Anamosa, Iowa 52205

Phone: 319-462-2344 or 888-962-2344

Email: [scaletec@scale-tec.com](mailto:scaletec@scale-tec.com)

**John Deere 1990  
30 Foot-1690 CCS Scale System  
Instruction Booklet**

**This product application is covered by U.S. Patents;**

**PATENTS: 6,732,667—7,059,258—7,273,017—7,357,087—7,448,335—7,523,710**

**PATENT PENDING: 12/427,915**

KEY	COL 2 QTY	COL 1 QTY	QTY	PART NO	DESCRIPTION
1	-	-	2	406031	WELD-TOP REAR BRKT (JD1990-03)
2	-	-	2	406024	WELD-BASE REAR PLATE (JD1990-07)
3	-	-	2	406051	WELD-TOP FRT BRKT (JD1990-05)
4	-	-	2	406014	WELD-30' FRT BRKT (JD1990-02)
5	-	4	4	406067	SCR - 3/4-16 X 2.0 HHCS ZP GRD 5
6	-	8	8	406068	SCR-3/4-10 X 3.5 HHCS GRD 8 ZP
7	-	8	8	405896	SCR -5/8-11 X 2.0 HHCS ZP GRD 5
8	4	-	4	406071	SCR-5/8-11 X 3.5 HHCS ZP SPECIAL
9	-	8	8	405858	WASH-5/8 FLAT WIDE ZP
10	-	8	8	405921	NUT-3/4-10 TOP LOCK ZP
11	6	14	20	406070	NUT-5/8-11 TOP-LOCK FLANGE ZP
12	-	-	4	404284	CELL-1.5 SQ DB-21 FT
13	-	-	1	404254	ASSY J-BOX 3PI/PT MOBILE
14	-	-	1	406074	CABLE-45FT J-BOX
15	-	-	1	406072	CABLE-POWER 6 FT 2-WIRE
16	-	-	1	403776	EZ400 1.902BL-IND
20	-	-	5	406025	BOLT-U 5/8-11 x 8.75W x 10.0L GRD 8 ZP

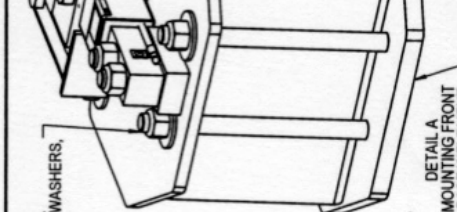
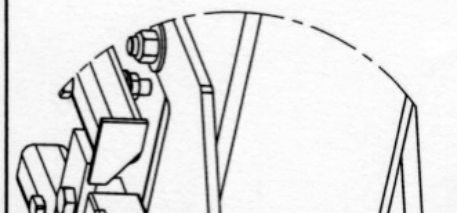
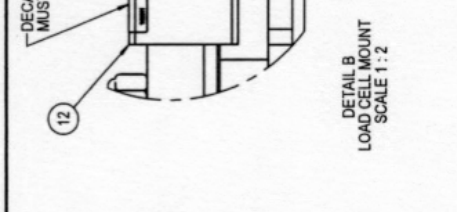
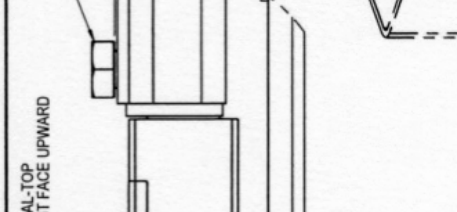
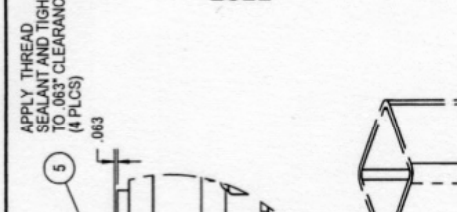
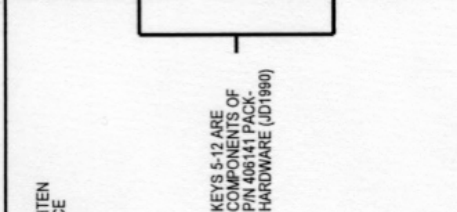

HMD REQ'D  
406141  
406143

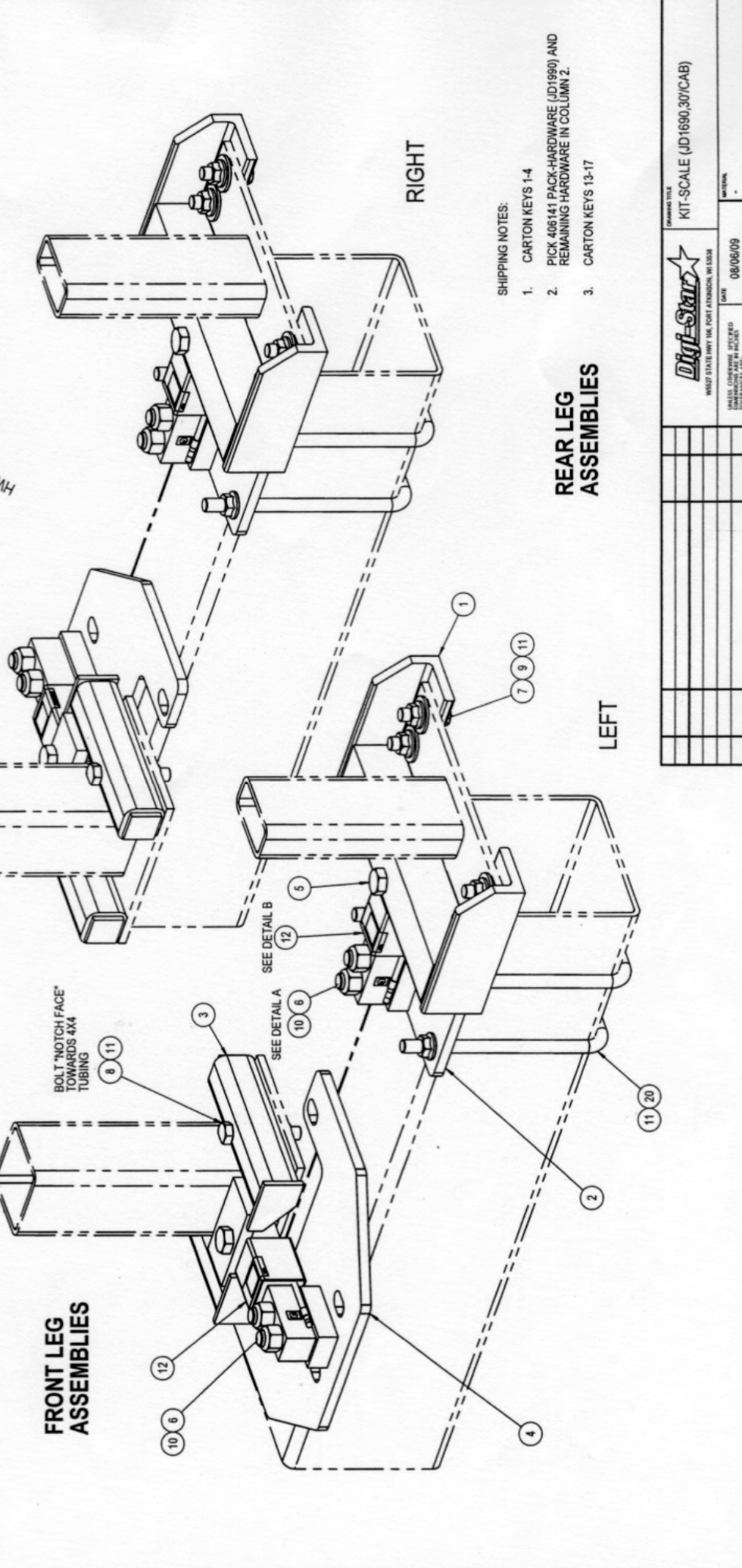

- SHIPPING NOTES:
1. CARTON KEYS 1-4
  2. PICK 406141 PACK-HARDWARE (JD1990) AND REMAINING HARDWARE IN COLUMN 2.
  3. CARTON KEYS 13-17

REV	DATE	BY	CHKD	DESCRIPTION
A	08/22	RELEASED		

DATE	08/06/09
SCALE	1:3.5
DRAWN BY	JZJC
CHECKED BY	
INCHES	1" = 1"
MILLIMETERS	1:1

DATE	08/06/09
SCALE	1:3.5
DRAWN BY	JZJC
CHECKED BY	
INCHES	1" = 1"
MILLIMETERS	1:1

DATE	08/06/09
SCALE	1:3.5
DRAWN BY	JZJC
CHECKED BY	
INCHES	1" = 1"
MILLIMETERS	1:1

DATE	08/06/09
SCALE	1:3.5
DRAWN BY	JZJC
CHECKED BY	
INCHES	1" = 1"
MILLIMETERS	1:1

DATE	08/06/09
SCALE	1:3.5
DRAWN BY	JZJC
CHECKED BY	
INCHES	1" = 1"
MILLIMETERS	1:1

DATE	08/06/09
SCALE	1:3.5
DRAWN BY	JZJC
CHECKED BY	
INCHES	1" = 1"
MILLIMETERS	1:1

DATE	08/06/09
SCALE	1:3.5
DRAWN BY	JZJC
CHECKED BY	
INCHES	1" = 1"
MILLIMETERS	1:1

DATE	08/06/09
SCALE	1:3.5
DRAWN BY	JZJC
CHECKED BY	
INCHES	1" = 1"
MILLIMETERS	1:1

DATE	08/06/09
SCALE	1:3.5
DRAWN BY	JZJC
CHECKED BY	
INCHES	1" = 1"
MILLIMETERS	1:1

DATE	08/06/09
SCALE	1:3.5
DRAWN BY	JZJC
CHECKED BY	
INCHES	1" = 1"
MILLIMETERS	1:1

DATE	08/06/09
SCALE	1:3.5
DRAWN BY	JZJC
CHECKED BY	
INCHES	1" = 1"
MILLIMETERS	1:1

DATE	08/06/09
SCALE	1:3.5
DRAWN BY	JZJC
CHECKED BY	
INCHES	1" = 1"
MILLIMETERS	1:1

DATE	08/06/09
SCALE	1:3.5
DRAWN BY	JZJC
CHECKED BY	
INCHES	1" = 1"
MILLIMETERS	1:1

DATE	08/06/09
SCALE	1:3.5
DRAWN BY	JZJC
CHECKED BY	
INCHES	1" = 1"
MILLIMETERS	1:1

DATE	08/06/09
SCALE	1:3.5
DRAWN BY	JZJC
CHECKED BY	
INCHES	1" = 1"
MILLIMETERS	1:1

DATE	08/06/09
SCALE	1:3.5
DRAWN BY	JZJC
CHECKED BY	
INCHES	1" = 1"
MILLIMETERS	1:1

DATE	08/06/09
SCALE	1:3.5
DRAWN BY	JZJC
CHECKED BY	
INCHES	1" = 1"
MILLIMETERS	1:1

DATE	08/06/09
SCALE	1:3.5
DRAWN BY	JZJC
CHECKED BY	
INCHES	1" = 1"
MILLIMETERS	1:1

DATE	08/06/09
SCALE	1:3.5
DRAWN BY	JZJC
CHECKED BY	
INCHES	1" = 1"
MILLIMETERS	1:1

DATE	08/06/09
SCALE	1:3.5
DRAWN BY	JZJC
CHECKED BY	
INCHES	1" = 1"
MILLIMETERS	1:1

DATE	08/06/09
SCALE	1:3.5
DRAWN BY	JZJC
CHECKED BY	
INCHES	1" = 1"
MILLIMETERS	1:1

DATE	08/06/09
SCALE	1:3.5
DRAWN BY	JZJC
CHECKED BY	
INCHES	1" = 1"
MILLIMETERS	1:1

DATE	08/06/09
SCALE	1:3.5
DRAWN BY	JZJC
CHECKED BY	
INCHES	1" = 1"
MILLIMETERS	1:1

DATE	08/06/09
SCALE	1:3.5
DRAWN BY	JZJC
CHECKED BY	
INCHES	1" = 1"
MILLIMETERS	1:1

DATE	08/06/09
SCALE	1:3.5
DRAWN BY	JZJC
CHECKED BY	
INCHES	1" = 1"
MILLIMETERS	1:1

DATE	08/06/09
SCALE	1:3.5
DRAWN BY	JZJC
CHECKED BY	
INCHES	1" = 1"
MILLIMETERS	1:1

DATE	08/06/09
SCALE	1:3.5
DRAWN BY	JZJC
CHECKED BY	
INCHES	1" = 1"
MILLIMETERS	1:1

DATE	08/06/09
SCALE	1:3.5
DRAWN BY	JZJC
CHECKED BY	
INCHES	1" = 1"
MILLIMETERS	1:1

DATE	08/06/09
SCALE	1:3.5
DRAWN BY	JZJC
CHECKED BY	
INCHES	1" = 1"
MILLIMETERS	1:1

DATE	08/06/09
SCALE	1:3.5
DRAWN BY	JZJC
CHECKED BY	
INCHES	1" = 1"
MILLIMETERS	1:1

DATE	08/06/09
SCALE	1:3.5
DRAWN BY	JZJC
CHECKED BY	
INCHES	1" = 1"
MILLIMETERS	1:1

DATE	08/06/09
SCALE	1:3.5
DRAWN BY	JZJC
CHECKED BY	
INCHES	1" = 1"
MILLIMETERS	1:1

DATE	08/06/09
SCALE	1:3.5
DRAWN BY	JZJC
CHECKED BY	
INCHES	1" = 1"
MILLIMETERS	1:1

DATE	08/06/09
SCALE	1:3.5
DRAWN BY	JZJC
CHECKED BY	
INCHES	1" = 1"
MILLIMETERS	1:1

DATE	08/06/09
SCALE	1:3.5
DRAWN BY	JZJC
CHECKED BY	
INCHES	1" = 1"
MILLIMETERS	1:1

DATE	08/06/09
SCALE	1:3.5
DRAWN BY	JZJC
CHECKED BY	
INCHES	1" = 1"
MILLIMETERS	1:1

DATE	08/06/09
SCALE	1:3.5
DRAWN BY	JZJC
CHECKED BY	
INCHES	1" = 1"
MILLIMETERS	1:1

DATE	08/06/09
SCALE	1:3.5
DRAWN BY	JZJC
CHECKED BY	
INCHES	1" = 1"
MILLIMETERS	1:1

DATE	08/06/09
SCALE	1:3.5
DRAWN BY	JZJC
CHECKED BY	
INCHES	1" = 1"
MILLIMETERS	1:1

DATE	08/06/09
SCALE	1:3.5
DRAWN BY	JZJC
CHECKED BY	
INCHES	1" = 1"
MILLIMETERS	1:1

DATE	08/06/09
SCALE	1:3.5
DRAWN BY	JZJC
CHECKED BY	
INCHES	1" = 1"
MILLIMETERS	1:1

DATE	08/06/09
SCALE	1:3.5
DRAWN BY	JZJC
CHECKED BY	
INCHES	1" = 1"
MILLIMETERS	1:1

DATE	08/06/09
SCALE	1:3.5
DRAWN BY	JZJC
CHECKED BY	
INCHES	1" = 1"
MILLIMETERS	1:1

DATE	08/06/09
SCALE	1:3.5
DRAWN BY	JZJC
CHECKED BY	
INCHES	1" = 1"
MILLIMETERS	1:1

DATE	08/06/09
SCALE	1:3.5
DRAWN BY	JZJC
CHECKED BY	
INCHES	1" = 1"
MILLIMETERS	1:1

DATE	08/06/09
SCALE	1:3.5
DRAWN BY	JZJC
CHECKED BY	
INCHES	1" = 1"
MILLIMETERS	1:1

DATE	08/06/09
SCALE	1:3.5
DRAWN BY	JZJC
CHECKED BY	
INCHES	1" = 1"
MILLIMETERS	1:1

DATE	08/06/09
SCALE	1:3.5
DRAWN BY	JZJC
CHECKED BY	
INCHES	1" = 1"
MILLIMETERS	1:1

DATE	08/06/09
SCALE	1:3.5
DRAWN BY	JZJC
CHECKED BY	
INCHES	1" = 1"
MILLIMETERS	1:1

DATE	08/06/09
SCALE	1:3.5
DRAWN BY	JZJC
CHECKED BY	
INCHES	1" = 1"
MILLIMETERS	1:1

DATE	08/06/09
SCALE	1:3.5
DRAWN BY	JZJC
CHECKED BY	
INCHES	1" = 1"
MILLIMETERS	1:1

DATE	08/06/09
SCALE	1:3.5
DRAWN BY	JZJC
CHECKED BY	
INCHES	1" = 1"
MILLIMETERS	1:1

DATE	08/06/09
SCALE	1:3.5
DRAWN BY	JZJC
CHECKED BY	
INCHES	1" = 1"
MILLIMETERS	1:1

DATE	08/06/09
SCALE	1:3.5
DRAWN BY	JZJC
CHECKED BY	
INCHES	1" = 1"
MILLIMETERS	1:1

DATE	08/06/09
SCALE	1:3.5
DRAWN BY	JZJC
CHECKED BY	
INCHES	1" = 1"
MILLIMETERS	1:1

DATE	08/06/09
SCALE	1:3.5
DRAWN BY	JZJC
CHECKED BY	
INCHES	1" = 1"
MILLIMETERS	1:1

DATE	08/06/09
SCALE	1:3.5
DRAWN BY	JZJC
CHECKED BY	
INCHES	1" = 1"
MILLIMETERS	1:1

DATE	08/06/09
SCALE	1:3.5
DRAWN BY	JZJC
CHECKED BY	
INCHES	1" = 1"
MILLIMETERS	1:1

DATE	08/06/09
SCALE	1:3.5
DRAWN BY	JZJC
CHECKED BY	
INCHES	1" = 1"
MILLIMETERS	1:1

DATE	08/06/09
SCALE	1:3.5
DRAWN BY	JZJC
CHECKED BY	
INCHES	1" = 1"
MILLIMETERS	1:1

DATE	08/06/09
SCALE	1:3.5
DRAWN BY	JZJC
CHECKED BY	
INCHES	1" = 1"
MILLIMETERS	1:1

DATE	08/06/09
SCALE	1:3.5
DRAWN BY	JZJC
CHECKED BY	
INCHES	1" = 1"
MILLIMETERS	1:1

DATE	08/06/09
SCALE	1:3.5
DRAWN BY	JZJC
CHECKED BY	
INCHES	1" = 1"
MILLIMETERS	1:1

DATE	08/06/09
SCALE	1:3.5
DRAWN BY	JZJC
CHECKED BY	
INCHES	1" =

## John Deere 1990 30 Foot 1690 CCS Scale Installation

1. Loosen the frame bolts on the front legs.
2. Disassemble the rear legs and remove the angle bracket mounted to the leg and the main frame.
3. Jack up one of the rear legs approximately 1 in.
4. Using the same bolts install the top bracket to the rear leg. Tighten these bolts at this time.
5. Assemble load cell to the rear base bracket by using the  $\frac{3}{4}$  x 3  $\frac{1}{2}$  in. bolts. Do not tighten bolts completely. You may have to slide load cell while aligning the base and top brackets. **TOP STICKER NEEDS TO BE ON TOP OF LOAD CELL!**
6. Bolt the rear base bracket to the main frame using the original frame bolts. The load cell is held to the rear top bracket with  $\frac{3}{4}$  x 2 in. bolts. The 2 in. bolts need to have thread lock applied to threads. **THIS BOLT CAN NOT BE COMPLETELY TIGHTENED DOWN, LEAVE 1/16 in. BETWEEN BOTTOM OF BOLT HEAD AND TOP BRACKET!**
7. Install brackets on other side. Do not tighten mounting bolts on rear legs until front legs are installed.
8. Disassemble the front legs from base plates. Jack up front leg and remove the base plate and yoke plate bolted to the main frame.
9. Install the front top bracket by using the  $\frac{5}{8}$  x 3  $\frac{1}{2}$  in. bolts. The flat edge on head of bolts needs to be next to the 4 in. x 4 in. tubing. The head of the bolt needs to be on the top side with the flange nut on the bottom side.
10. Assemble load cell to the front base bracket by using  $\frac{3}{4}$  x 3  $\frac{1}{2}$  in. bolts. Do not tighten bolts completely. You may have to slide load cell while aligning base and top brackets. **TOP STICKER NEEDS TO BE ON TOP OF LOAD CELL!**
11. Using the same frame bolts, bolt the front base plate to the main frame with the yoke plate on the bottom. (Refer to picture)
12. The load cell is held to the front top bracket with  $\frac{3}{4}$  x 2 in. bolts. The 2 in. bolts need to have thread lock applied to the threads. **THIS BOLT CAN NOT BE COMPLETELY TIGHTENED DOWN, LEAVE 1/16 in. BETWEEN BOTTOM OF BOLT HEAD AND TOP BRACKET!**

13. Install brackets on the other front leg. When all brackets are installed tighten all of the frame bolts.

Load Cell Connection:

The indicator is designed to operate with strain gage load cells. The load cells are connected to the terminal board inside the Junction Box. The indicator can be mounted on the railing on the rear of the seeder. Use parts H151618 (two each) and H136110 (two each) and bolt it to the indicator mounting bracket. This will allow you to swivel to the rear while filling and swivel to the front for planting.

Power Cord:

Red and white wire positive, black wire is negative.

Cab Mounting:

A 45 foot cable can be added to the junction box if cables are too short to reach tractor cab.

If you have any questions regarding the installation or the product, give us a call at (319)-462-2344, or toll-free +1-888-962-2344.

**See the following pages for pictures, and also for instructions on wiring and scale use.**

# Leg Hardware

3/4" x 3 1/2" Bolts  
and 3/4" Locknuts

2" x 5/8" Bolts

3/4" x 2" Fine Threaded

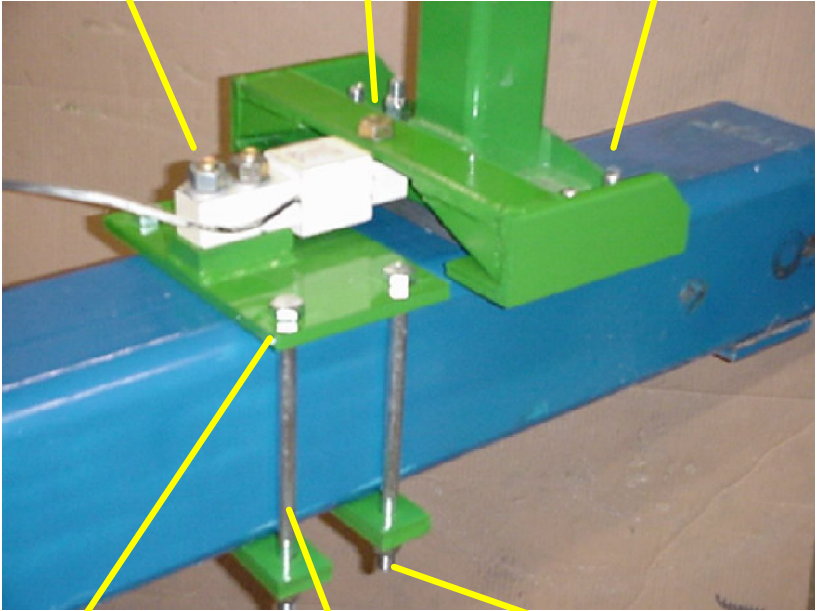

5/8" Washers

5/8" x 11" Bolt  
or 5/8" x 10 1/2" x 8" U-bolt

5/8" Flange  
Locknut

# Leg Bracket Assembly

Weigh Bar

Top Bracket

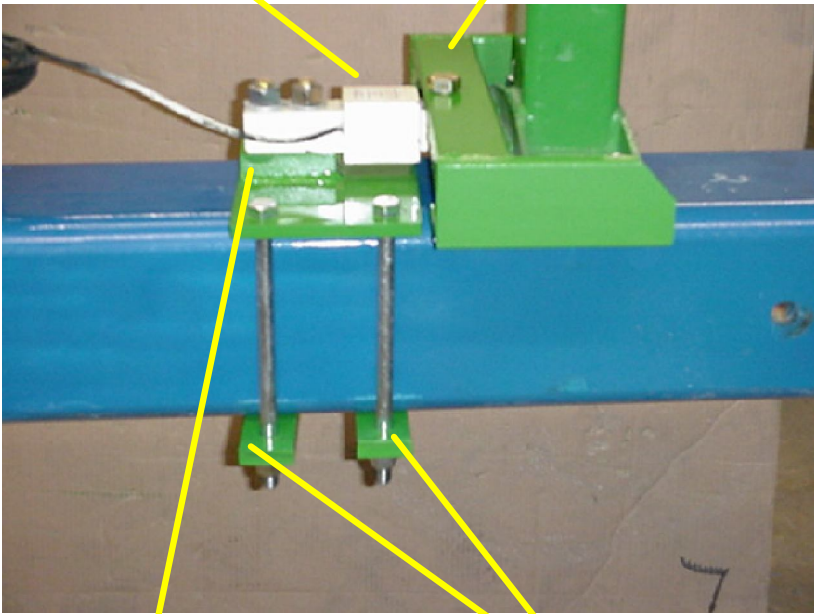

Base Plate

Frame Plates  
or 5/8" x 10 1/2" x 8" U-bolts

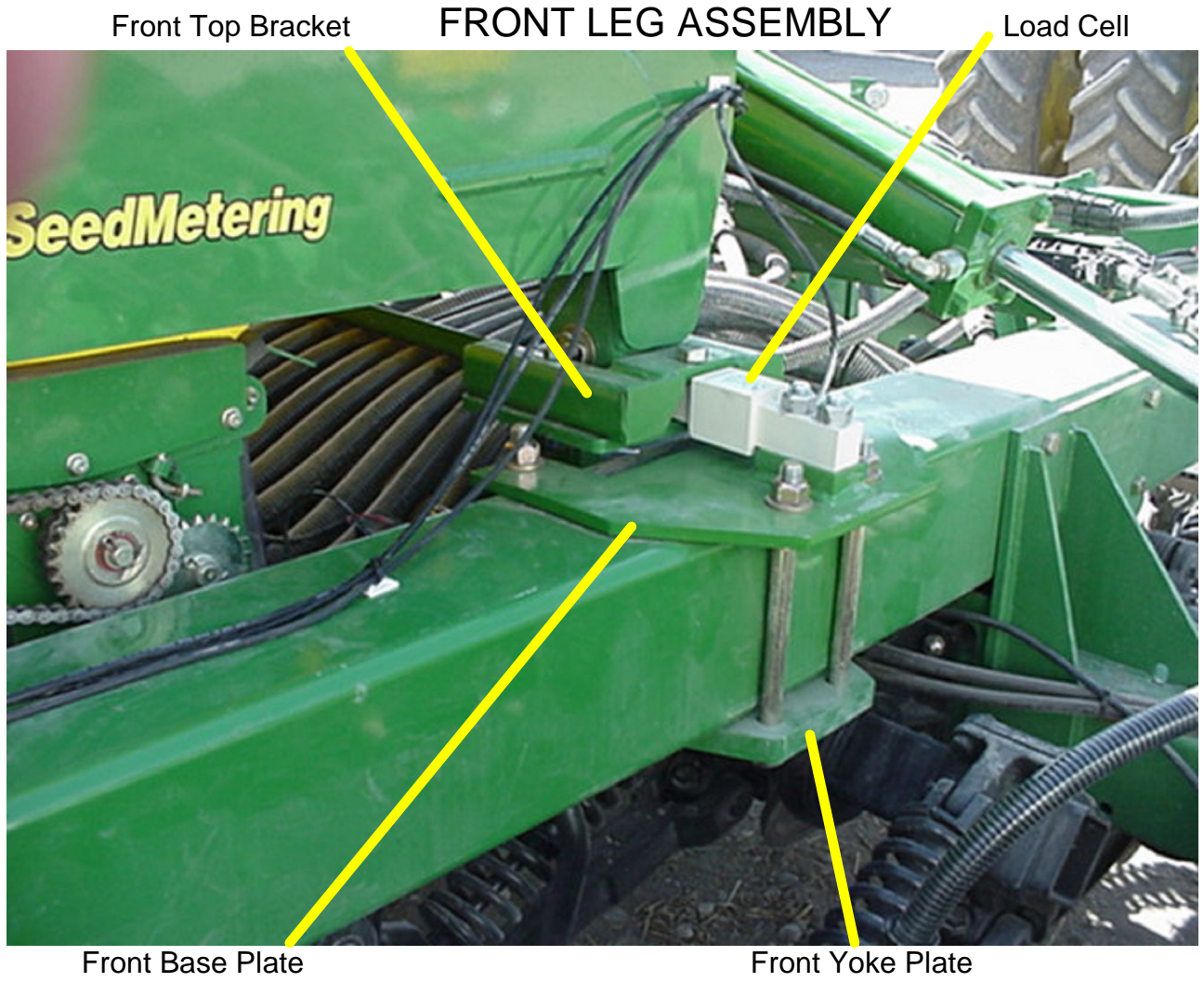

Front Top Bracket

FRONT LEG ASSEMBLY

Load Cell

Front Base Plate

Front Yoke Plate

**Power Connection:**

The power cable should be connected directly to a vehicle battery or regulated power supply. The scale end of the power cable is attached to the J901 connector located on the bottom panel of the scale.

Connect the RED wire from the power cable to +12 VDC and the BLACK wire to GROUND. The indicator is fused internally at 4 amps.

Power Cable Connections:

<b>Wire color</b>	<b>Wire Function</b>
Red	<i>Battery (+12 VDC)</i>
Black	<i>GROUND</i>

**Load Cell Connection:**

The indicator is designed to operate with strain gage load cells. The indicator will normally be supplied with a “J-BOX” cable going between the scale and the load cell junction box. Extension kits are available from your dealer in various lengths.

To connect the load cells, attach the junction box cable to the J902 or J903 connector on the bottom panel of the scale.

**How to use Drill Scale with a Digi-Star GT460 or GT400 Indicator**

1. Turn indicator on.
2. Push the “ZERO” button to zero out the scale.  
The arrow will be pointing towards “GROSS” on the display.
3. Fill the drill with seed. The GROSS weight is your inventory of seed in the drill.
4. To set population rate, stop in a level location with the drill row units up.
5. Check your acre counter.
6. Push the “START” button on the display.  
The display will show zero.  
An arrow will be pointing towards “TARE” on the display.
7. Drill 3 acres and stop in a level location with the drill row units up.
8. Divide the acres planted the amount of seed used.  
This gives the pounds per acre of seed.
9. Press “STOP”, the indicator will go back to displaying the inventory of seed in the drill.  
The arrow will be pointing towards “GROSS” on the display.