

Chute Weigh



Ideal for livestock weighing and herd management!

The Chute Weigh system is ideally suited for installation under a manual or hydraulic livestock squeeze chute, or livestock scale.

The ease of installation and setup, allows the system to be accurately weighing in just minutes. Installation can be portable or permanent depending on specific application.

Features & Benefits

Large weight capacity— 10,000 lb. gross weighing capacity (5000 lb per weigh bar).

Low profile— Less than 3.50 inches tall.

Heavy-duty construction— Super heavy-duty steel chassis construction.

Easy mounting— Mounting under manual or hydraulic livestock squeeze chutes.

Weigh bar cables— Tough polyurethane weigh bar cables, 20 ft long.

Weatherproof construction— Aerospace-developed sealing agent provides ultimate protection against moisture and ensures long term durability in harsh agricultural environment.

Herd management— Weight indicator is compatible with various herd management EID software packages.

Options

Choice of Avery Weigh-Tronix Indicators

615/XL— The 615 and 615XL indicators provide simple yet accurate and reliable livestock weighing.

M915A— The Model 915A makes the chore of weighing livestock quicker and easier. Features include auto-LOC capabilities, statistical functions, 1000 weight memory and auto weight recording.

Power cable— 12 VDC power cable for external battery.

Transformer— 115VAC wall mount transformer.



615/XL

M915A

Chute Weigh

Specifications

Capacity: 10,000 lb per set (5,000 lb/ each)
Material: Alloy Steel Weigh Bars
Finish: Gray baked-on powder paint
Accuracy: $\pm 0.25\%$
Full Scale Output: 0.76 mV/V @ 10,000 lb (system of 2)
Input Resistance: 350 ohms \pm 20 ohms
Zero Balance: ± 0.5 mV/V

Cable Length: 20 ft
Shipping Weight: 61 lb
Warranty: Three years

5 Pin Connector Color Code:

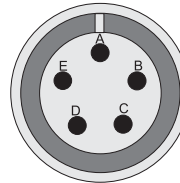

B Green + Excitation
 D Black - Excitation
 C White + signal
 A Red - signal
 E Orange Shield

Dimensional Drawing

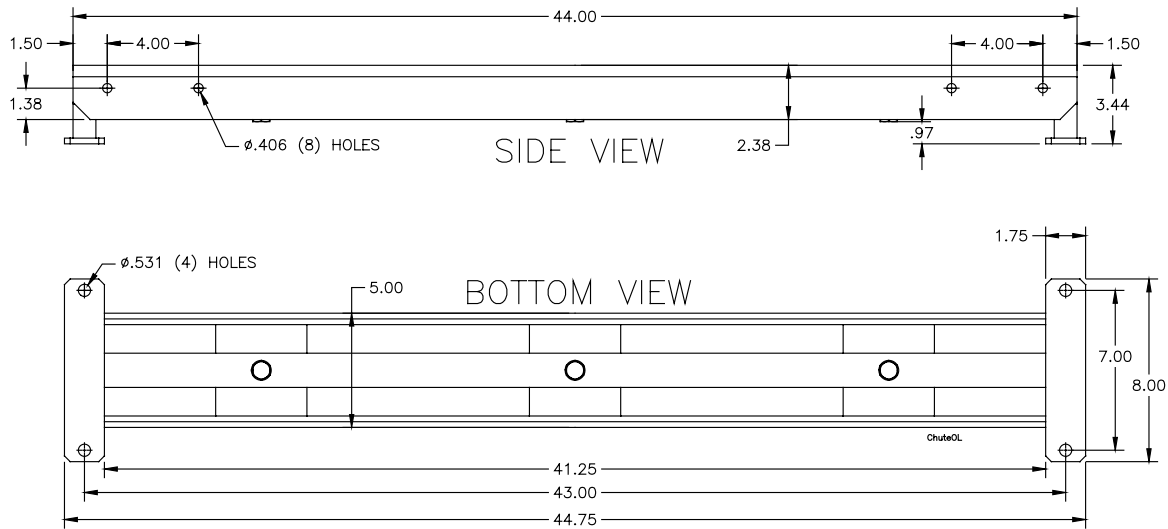

Avery Weigh-Tronix, LLC
 1000 Armstrong Dr.
 Fairmont, MN 56031 USA
 Telephone: 507-238-4461
 Facsimile: 507-238-8283
 e-mail: ag@weigh-tronix.com
 www.agscales.com

