

WEIGH-TRONIX



Model 915A Indicator User's Manual

UNITED STATES

This equipment has been tested and found to comply with the limits for a Class A digital device, pursuant to Part 15 of the FCC Rules. These limits are designed to provide reasonable protection against harmful interference when the equipment is operated in a commercial environment. This equipment generates, uses, and can radiate radio frequency energy and, if not installed and used in accordance with the instruction manual, may cause harmful interference to radio communications. Operation of this equipment in a residential area is likely to cause harmful interference in which case the user will be required to correct the interference at his own expense.

CANADA

This digital apparatus does not exceed the Class A limits for radio noise emissions from digital apparatus set out in the Radio Interference Regulations of the Canadian Department of Communications.

Le present appareil numerique n'emet pas de bruits radioelectriques depassant les limites applicables aux appareils numeriques de la Class A prescrites dans le Reglement sur le brouillage radioelectrique que edicte par le ministere des Communications du Canada.



CAUTION

Risk of electrical shock. Do not remove cover. No user serviceable parts inside. Refer servicing to qualified service personnel.

Weigh-Tronix reserves the right to change specifications at any time.

Table of Contents

Table of Contents	3
Specifications	4
Options	5
Introduction	7
Front Panel	7
Keys	7
Cable Connections and Power Requirements	8
Indicator Operation	9
Gross Weighing	9
ID Number Entry	9
View Current ID	10
Clear Current ID	10
Animal Weighing	10
How to View the Animal Statistics	11
Printing Reports	11
To Clear All Statistics From Memory	12
Setting Auto-LOC	12
Viewing and Setting the Time	12
Viewing and Setting th Date	12
Checking Battery Voltage	13
Diagnostic Tests	13
Troubleshooting	15
Power-On	15
Stalled Display Following Power-On	16
Indicator Lock-Up	17
Inaccurate Weight Readings	17
Alarm Light Function	18
Measuring Supply Battery Voltage	18
Service Repairs	18
Display Messages	19
Miscellaneous Information	19
Mounting the Model 915A	19
RD912 Remote Display	20
Optional Radio Remote Transmitter (XM710) and Receiver	20
User's Menu	21
Appendix A: Customizing Printouts	22
Layout 1 through 5	22
ASCII	22
To Delete All ASCII Characters	23
Enabling Auto-Print	23

Pages are numbered consecutively beginning with the cover page.

Specifications

Indicator Enclosure	Impact, dust, and water resistant - structural polycarbonate enclosure stands up to inclement weather and high vibration mobile farm applications. Standard Weigh-Tronix mounting bracket. (Dimensions: 8.75 high x 10.5 wide x 6.5 deep)
Display	8 digit, seven segment LCD, 1.0 inch high characters, 10 annunciators*, and fiber optic back-lighting. * annunciators-GROSS, TARE, NET, ID, MEMORY, MOTION, TOTAL, AUTO, LB, and KG
Display Rate	One, two, or five times per second
Accuracy	+/- 0.1% of applied load or +/- one division, whichever is greater
Linearity	+/- .01 % of capacity
Repeatability	+/- .01% of capacity, +/- one division, whichever is greater
Power Requirements	Typical: 12 VDC @ 95 mA (1.14 watts) 12VDC @ 180 mA (2.16 watts) for 5-pin 4 weigh-bars Range: 10 DVC @ 89 mA (0.9 watts) to 18 VDC @ 555 mA (10 watts). Negative ground system.
Environment	-20° F to 140° F (-29° C to 60° C) to 95% non-condensing humidity
Weigh-bar® Drive Capacity	Ten 350 ohm Weigh-bars
Calibration	Front panel calibration and spanning for all types of weigh bars and load cell applications up to 999999 lb. or kg.
Divisions	.01, .02, .05, .1, .2, .5, 1, 2, 5, 10, 50, 100, 200, 500 lb. or kg.
Zero Balance Range	+/- 1 mV/V via front panel push button
Analog Span	0.20 mV/V to 1.0 mV/V (full scale)
Automatic Zero Tracking	OFF, +/-0.5, 1.0, 2.0, 3.0, 5.0, 10.0 divisions
Motion Detection Window	OFF, +/-0.5, 1.0, 2.0, 3.0, 5.0, 10.0 divisions
Motion Filtering	Normal, intermediate, and high
Alarm Output	Comes on standard in the Auto Accumulate/Print mode when Auto--Loc takes place.

Options

RS232 serial output Includes battery backed up time and date
Baud rate selectable: 9600, 4800, 2400, 1200, 600 and 300
xon/xoff, 8 data bits, one stop bit, no parity
Initiate serial transmission through- print button, enquire characters, and auto
print after accumulate and after motion ceases.
Five format selectable printouts along with single line programmable (40)ASCII
characters.

Remote Display Output To be used with the RD912 remote display.

Remote (XM710) Includes optional remote radio receiver, and transmitter.
Two separate inputs on the M915A will each be programmable to function as
Zero, G/N, RM, M+, M-, or Print.
Frequency: 303 MHz
Frequency on by key switch, causes activation of Input-1 or Input-2

This page left intentionally blank.

Introduction

The Model 915A is a general purpose animal weight indicator designed to operate at 12VDC. It has a companion remote display called the RD912. The indicator can record 1000 animal weighments and give statistics on count, total weight, average weight, highest weight, and lowest weight.

Front Panel

Figure 1 shows the Model 915A front panel.

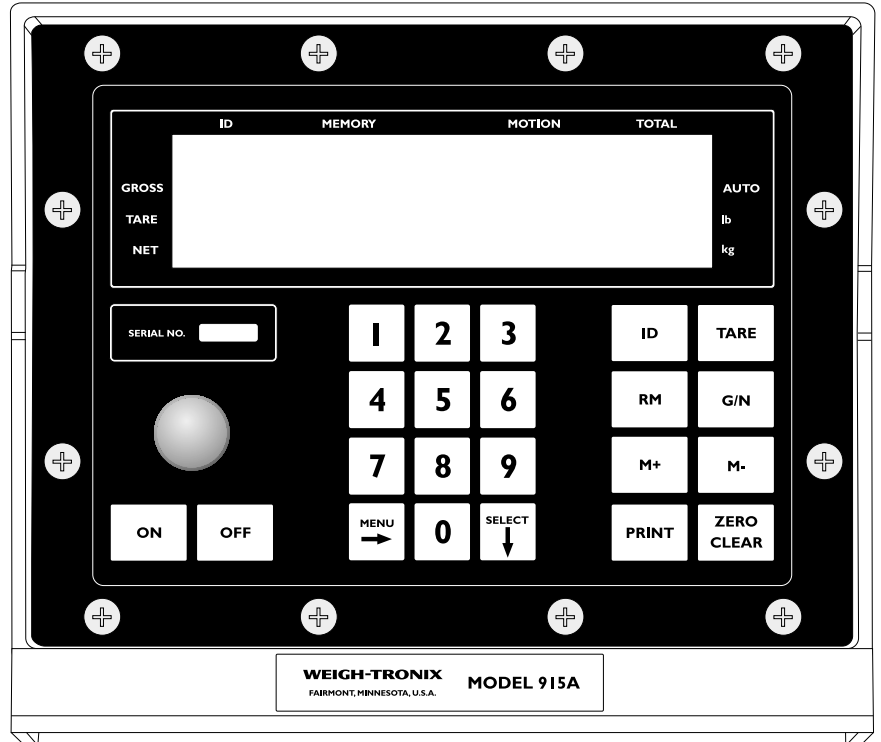

Figure 1
Model 915A indicator

The front panel consists of the digital display window with annunciators, numeric keypad and the following keys:

Keys		
ON	Use this key to power up the 915A indicator	
OFF	Use this key to power down the 915A indicator	
MENU	Use this key to access the menus and scroll right in the menu structure	
SELECT	Use this key to make selections in the menus and to scroll down in the menu structure	
ID	Use this key to access the ID function	
TARE	Disabled	
RM	Use this key to recall a weight stored in memory	

G/N	Use this key to escape back to gross weighing
M+	Use this key to record/add a displayed weight to the memory
M-	Use this key to delete the last recorded weight in memory
PRINT	Use this key to output displayed information to a peripheral device
ZERO/CLEAR	Use this key to zero the scale or clear a keyed in value from the display.

Cable Connections and Power Requirements

Make sure all cables are connected as shown in Figures 2 & 3.

Voltage to the Model 915A must be 10-18 volts DC, negative ground only. If voltage is between 8-10 volts, **Lo-bAt** is displayed on the indicator. Dropping below eight volts will cause the Model 915A to automatically shut itself off, protecting the battery from being completely drained. Consult the *Model 915A Service Manual* for instructions on disabling the automatic shut-off.

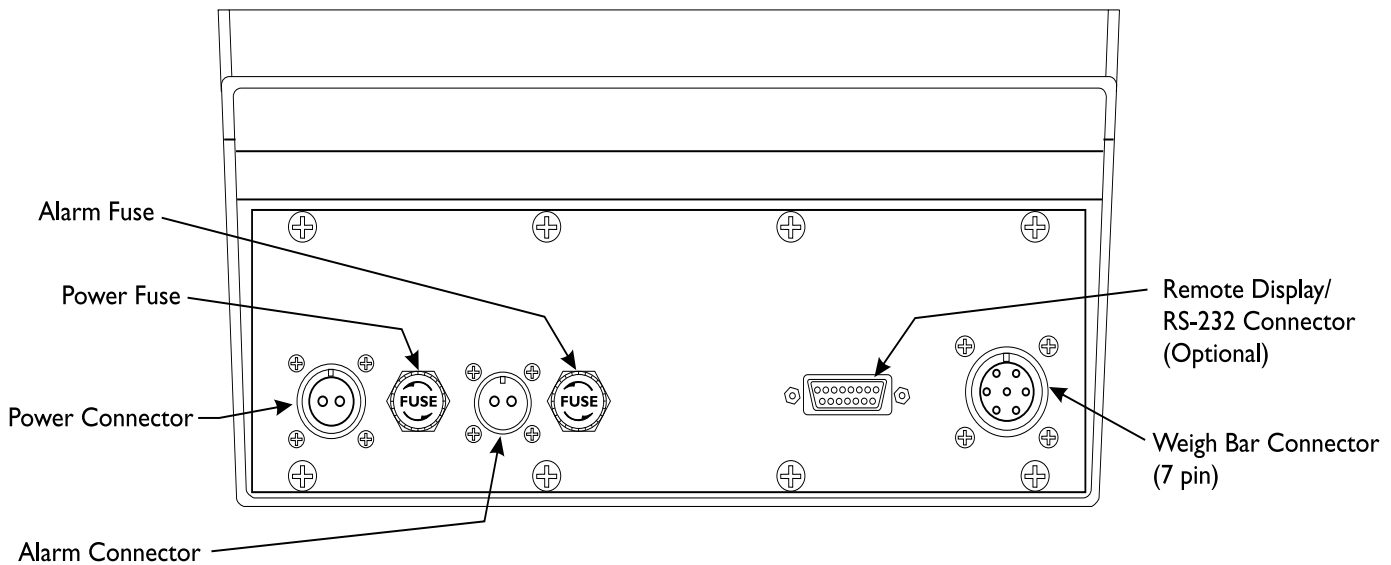

Figure 2
Indicator with One Weigh Bar connector

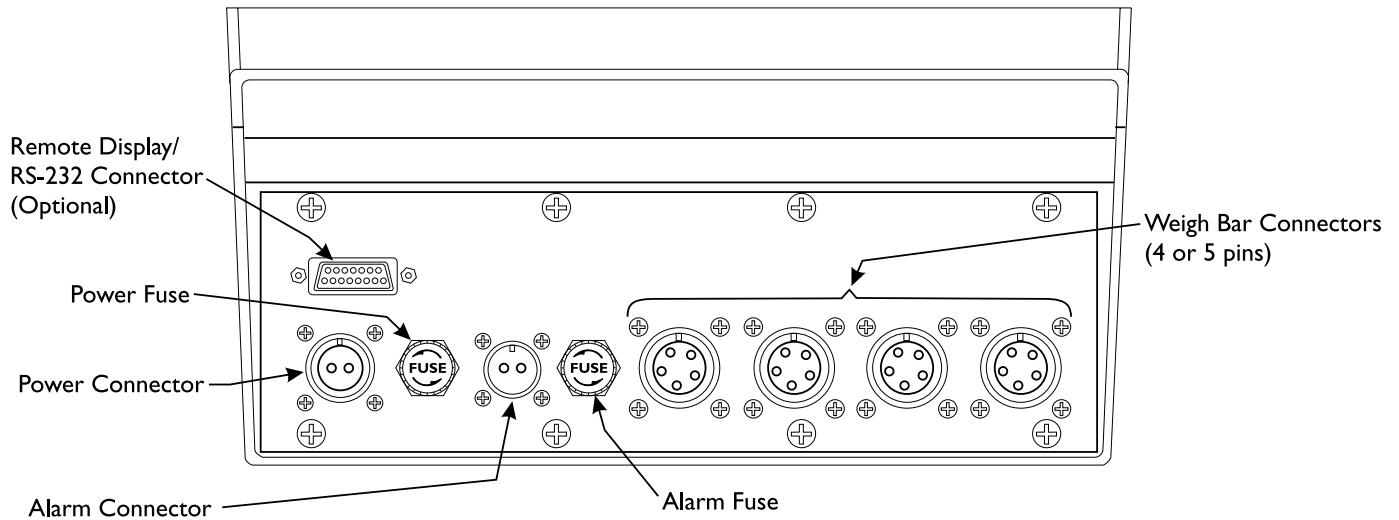

Figure 3
Indicator with four Weigh Bar connectors

Indicator Operation

Gross Weighing

*Key names are in “**BOLD UPPER CASE**” letters.
Displayed characters are “***Bold Italicized***”.
Annunciator labels are “UPPER CASE”.*

1. Power up the indicator by pressing **ON**.
Indicator powers up in mode that was active prior to turning off.
2. Verify the scale is empty and zero the scale by pressing **ZERO**. **0** is displayed. Zeroing can only occur if there is no motion on the scale.
3. Place weight on the scale. Gross weight is displayed.

ID Number Entry

The ID number can be used as a group identification or you can set up the 915A for Auto-Print and use ID to enter each animal’s ID number. See the section Printing Reports.

- You may enter an 8 digit numerical ID number to be included in the printouts
1. From the gross weighing mode use the keypad and enter the ID number. ID number is shown on the display.
 2. Press **ID**. The ID annunciator is turned on. ID number is displayed for 2 seconds, then returns to the gross mode.

View Current ID

If no ID is currently programmed, then ID key displays "no Id" for 2 sec., and returns to the Gross mode.

1. Press **ID**.

Current ID is shown for two seconds and then returns to the gross mode.

Clear Current ID

1. Press **ID** to display current ID.
2. Press **ZERO/CLEAR** while ID is displayed.

Current ID is displayed.

ID is cleared, and returns to gross mode.

Animal Weighing

*Layout #3, shown in Printing Reports, will be printed if you press **M+** with Auto-Print enabled. It will also be printed if Auto-Loc is enabled.*

You can perform animal weighing with Auto-LOC on or off. See the section *Configuring Auto-Loc*.

With Auto-LOC on:

As the animal walks on the scale and the weight stabilizes, the alarm light comes on for two seconds and the weight is automatically stored in the first available record (1-1000).

The display will show the record number and the locked weight until the weight drops by 20% or more. At this point the display returns to live gross weighing and the alarm light turns off.

In this mode the M+/M- keys are disabled.

With Auto-LOC off:

After the animal walks on the scale, you must press the **M+** key to record the weight. The memory channel and weight will remain displayed and the alarm light will come on for two seconds. You cannot record the weight again until the weight drops by 20%. If you try, the display will show **Can't**.

If you want to erase a weight you recorded in error, press the **M-** key. The display will show the count with the new locked-on weight. This can be done with or without the animal on the scale.

How to View Individual Animal Weights

Follow these steps to view each animal's weight:

1. From gross weighing mode, press the **RM** key. . .
2. Press the **M+** or **M-** key to scroll through the list of animals and their weights. To scroll more rapidly through the list, press and hold the **M+** or **M-** key.
3. Press the **G/N** key to return to gross weighing mode.

The last recorded weight and channel number is displayed.

How to View the Animal Statistics

Once you have recorded a series of animal weights you can view the results by entering the **StAts** item in the user menu. See Figure 6.

Under **STATS** you can view the following by using the **SELECT** and **MENU** keys:

- total count of animals weighed
- total weight of all animals weighed
- average weight of all animals weighed
- highest recorded animal weight
- lowest recorded animal weight

1. From gross mode press **MENU** and. . . **StAts** is displayed.
2. Press **SELECT** The first stat, **Count**, is displayed.
3. Press **SELECT** to see the total number of animals weighed.
4. Press **SELECT** again to return to the **StAts** display.
5. Press **MENU** to go to the next stat. Repeat steps 3-5 to see all the stats.
6. Press **G/N** to return to gross weighing mode.

Printing Reports

*If AUTO-PRINT is enabled (see your Appendix A) and AUTO-LOC is on, Layout #3, shown at right, is printed as soon as an animal's weight is stable. If AUTO-LOC is off when pressing **M+**, Layout #3 is automatically printed.*

You can customize the first line in the examples at right (Model 915A). See Appendix A.

Also, ID will only be printed if an ID is entered.

To print out a report, press the **PRINT** key. One of the following layouts will be printed depending on which you have chosen through the configuration menu. See *Appendix A* for instructions on choosing a layout.

```
MODEL 915A
ID 12345678
02/03/00 10:12:02
0001, 684 lb
0002, 788 lb
0003, 690 lb
0004, 790 lb
0005, 915 lb
0006, 624 lb
0007, 787 lb
0008, 679 lb
0009, 845 lb
0010, 914 lb
COUNT: 0010
TOTAL: 7716 lb
AVERAGE: 771 lb
HIGH: 915 lb
LOW: 624 lb
```

Layout #1

```
MODEL 915A
ID 12345678
0001, 684 lb
0002, 788 lb
0003, 690 lb
0004, 790 lb
0005, 915 lb
0006, 624 lb
0007, 787 lb
0008, 679 lb
0009, 845 lb
0010, 914 lb
```

Layout #2

1019 lb

Layout #5

0010, 12345678, 914 lb

Layout #3

```
MODEL 915A
ID 12345678
02/03/00 10:12:02
COUNT: 0010
TOTAL: 7716 lb
AVERAGE: 771 lb
HIGH: 915 lb
LOW: 624 lb
```

Layout #4

To Clear All Statistics From Memory

Follow these steps to remove all the statistics from memory.

1. From gross mode repeatedly press **MENU** until. . . **Clr-Stat** is displayed.
2. Press **SELECT**. . . **YES** or **no** is displayed.
3. Use the **MENU** key to toggle between the choices. Press **SELECT** when the choice you want is displayed. . . Stats are cleared or not depending on your choice.
4. Press the **G/N** key to return to gross weighing mode.

Setting Auto-LOC

Follow these steps to turn Auto-LOC on or off:

1. From gross mode repeatedly press **MENU** until. . . **Auto-LOC** is displayed.
2. Press **SELECT**. . . **on** or **OFF** is displayed.
3. Press **MENU** to toggle between the choices. Press **SELECT** when the choice you want is displayed. **Auto-LOC** is displayed.
4. Press the **G/N** key to return to gross weighing mode.

Viewing and Setting the Time

Refer to User's Menu section of this manual.

1. From gross mode repeatedly press **MENU** until. . . **Hour** is displayed.
2. Press **SELECT**. . . The time will be displayed in hours, minutes and seconds.
3. Enter the correct time allowing spaces for hours, minutes and seconds. For example, 1:59 would be entered as 15900.
4. Press **SELECT**. . . **Hour** is redisplayed.
5. Press **G/N** to return to gross weighing mode.

Viewing and Setting the Date

Refer to User's Menu section of this manual.

1. From gross/net mode repeatedly press **MENU** until. . . **Date** is displayed.
2. Press **SELECT**. . . The date is displayed in month, day, year. (For kg: day, month, year)

3. To change the date, key in the new numbers.
4. Press **SELECT** . . . **Date** is redisplayed.
5. Press **G/N** to return to gross weighing mode.

Checking Battery Voltage

Refer to User's Menu section of this manual.

1. From gross/net mode repeatedly press **MENU** until. . . **battErY** is displayed.
2. Press **SELECT** . . .
The input voltage of the battery or power source will be displayed. Voltage to the Model 915A must be 10-18 volts DC. If voltage is between 8-10 volts, **Lo-bAt** is displayed on the indicator. Dropping below eight volts will cause the Model 915A to automatically shut itself off, protecting the battery from being completely drained.

Diagnostic Tests

There are four tests available to assist troubleshooting in these areas:

- display
- buttons
- serial
- relay

1. From gross/net mode repeatedly press **MENU** until. . . **tESt** is displayed.
2. Press **SELECT** . . . **diSPIAY** is displayed. This is the display test.
3. Press **SELECT** to perform a test of the display segments and annunciators. . .
The display alternately lights all the display segments and annunciators. Press **SELECT** to end the test

or

Press **MENU** twice to go to the next test. . .

buttonS is displayed. This is the buttons test.

You can press **SELECT** at any time to return to the **rELAY** display.

4. Press **SELECT** to perform a test of the front panel buttons. . .

or

Press **MENU** to go to the next test. . .

When you press any key, that key name will appear in the display. Press **MENU** to stop the test. Display will show **SErIAI**.

SErIAI is displayed.
5. **SErIAI** is the serial test. This will tell you if pins 2 and 3 are connected. If they are connected **loop** is displayed when you press **SELECT**.

no loop is displayed when you press **SELECT** if pins 2 and 3 are not connected.
6. Press **MENU** to go to the next test. . .

rELAY is displayed. Use this test to check alarm light function.
7. Press **SELECT**. . .

OFF is displayed.
8. Press **MENU** once to cause the light to flash on and off. . .

press **MENU** again to cause the light to stay on. . .

press **MENU** again to shut off the light. . .

FLASH is displayed.

on is displayed.

OFF is displayed.
9. Press **SELECT**. . .

rELAY is displayed.
10. Press **MENU**. . .

tESt is displayed.
11. Press **MENU**. . .

SoFt is displayed. This lets you see the part number and revision level of the software.
12. Press **SELECT**. . .

First part of the software number is displayed.
13. Repeatedly press **MENU** to scroll through the part number and revision level and return to the **SoFt** display.
14. Press **MENU** one more time and you are back in the gross/net mode.

Troubleshooting

If you experience problems in the operation of your system, read through these troubleshooting steps and perform those which are appropriate. This information may help you to correct the following operational difficulties without calling your supplier or sending your equipment in for repair:

- Power-on
- Stalled Display Following Power-on
- Indicator Lock-up
- Inaccurate Weight Readings
- Alarm Light Malfunction
- Measuring the Supply Battery Voltage

Instructions for sending an indicator in for repair are provided in the last section under *Service Repairs*.

Power-On Failure

If your indicator doesn't power-on, check the following possible problem sources in the order given. Attempt to power-on after trying each of these four troubleshooting steps:

1. Check Battery Voltage. Required voltage is 10-18 volts DC negative ground. If the voltage is between 8-10 volts, the indicator will display *Lo-bAt*. The indicator will automatically turn off if the incoming voltage drops below 8 volts or rises above 18 volts.
2. Disconnect and Check Power Cable Connector at the vehicle or AC to DC converter, clean if necessary, and reconnect.
3. Replace Fuses. Sometimes, a bad fuse can be recognized by an obvious break in the wire filament. However, such a break is not always observable, and getting a successful power-on after changing a fuse is often the only way of knowing that the fuse was indeed defective.

Make sure new fuses are the proper size and have a current rating of five amperes. Using a fuse with too high a current rating can cause costly damage to the indicator and will void your warranty. The same is true for substituting wire, a nail, or any other object in place of a fuse.

Place nothing in the fuse connector except a proper fuse.

Change one fuse at a time (see instructions below). Try to power-on after changing the first fuse; if unsuccessful, change the second fuse and try to power on again. If changing the second fuse fails to allow successful power-on, proceed to the next trouble shooting step.

To replace a fuse, first locate fuse caps on the bottom panel of the indicator. Then:

1. Turn cap counterclockwise and lift out fuse & cap assembly.
 2. Remove old fuse from cap and insert new fuse.
 3. Replace fuse & cap assembly in fuse connector.
4. Test Indicator and Cables to isolate the source of the problem.
 - a. Disconnect all cables on bottom panel of Indicator except for power cable. Do disconnect Weigh Bar[®] cables, and, if present, alarm cable and printer/remote display cable.

- b. Now try powering-on. If this is not successful, your problem is in the indicator and you should contact your supplier.
- c. If you are able to power-on with only the power cable connected, your problem is most likely not in the indicator; continue troubleshooting.
- d. With power still on, plug in cables, one at a time — Weigh Bar® cables first, then alarm cable, then printer/remote display cable — until plugging in one of the cables causes the indicator to shut off. That cable is the bad one and needs to be repaired or replaced.

Stalled Display Following Power-On

This category of problems can exhibit any one of the following symptoms:

- An **illegible display** that cannot be zeroed and from which you cannot exit;
- A **legible display**, such as *HELLO*, that cannot be zeroed and from which you cannot exit;
- An **illuminated backlight** with no characters displayed and allowing no exit.
- If the red illumination on the display is visible, telling you the indicator has power (on a sunny day you may have to shade the display), you can possibly restore the display function by doing a **Reinitialization** (explained below).

To Reinitialize a Stalled Indicator:

1. Press **OFF**.
2. Press **ZERO/CLEAR** and hold in, while you
3. Press and release **ON**.
4. Then release **ZERO/CLEAR**.

If the display says *HI* instead of *HELLO* following a reinitialization power-on, your indicator has a potential problem and should be checked. Contact your supplier.

Indicator Lock-Up

A locked up indicator is represented by an illuminated alarm light and a display of **Error**.

1. Shut off the alarm by pressing any key.
2. Test the Weigh Bar[®] cables to isolate the source of the lock up problem, as follows:
 - a. Disconnect all Weigh Bars[®].
 - b. Try to zero the indicator by pressing **GROSS** and **ZERO/CLEAR**.
 - If you are **unable** to zero the indicator with the Weigh Bars disconnected, the problem is in the indicator and you should contact your supplier.
 - If you are **able** to zero your indicator with the Weigh Bars disconnected, then the problem is probably in the cabling or the Weigh Bars and you should continue troubleshooting.

3. Reconnect all Weigh Bars. You will see **Error** displayed again.
4. If your Weigh Bar connectors have the four-pin configuration, disconnect one Weigh Bar and connect an adapter plug in its place.

If your Weigh Bar connectors have the five-pin configuration, disconnect one Weigh Bar. No adapter plug is necessary.

5. Try to zero the indicator.

Repeat Steps 4 and 5 with each Weigh Bar cable, making sure each time that all cables are connected except the one you removed (for five-pin connector) or replaced with an adapter plug (for four-pin connector).

A defective Weigh Bar may be easily recognized with this method — when a defective bar is replaced with an adapter plug (for four-pin connector), or removed (for five-pin connector), the indicator will zero properly.

Inaccurate Weight Readings

First: Visually inspect the scale system for apparent problems and improper installation:

1. Check each cable, from source to indicator, for stress, cuts, breaks, or abrasions.
2. Unplug and reconnect each connector at the indicator to verify that it is tight and making good contact.
3. Check between supporting structure and weighing structure for debris that might restrict Weigh Bar[®] movement.
4. Make sure the supporting structure and weighing structure do not touch each other at any point except at the Weigh Bars[®].

Next: Compare weight readings for all Weigh Bars:

Position a person or heavy object on the platform above each Weigh Bar, one bar at a time, and compare weight readings for the same person or same object.

For each weighing, the weight itself will be off-center, favoring a single Weigh Bar; therefore, none of the readings will be accurate.

However, your readings obtained by weighing the same person or object above each Weigh Bar should be nearly identical to each other. A single Weigh Bar reading that is significantly different from the others is probably defective.

Alarm Light Function

If your external alarm works properly but the alarm light fails to illuminate when it should, a problem exists with the alarm light. Please send in the indicator for repair.

Measuring Supply Battery Voltage

To check input voltage to indicator (battery voltage):

1. Press **MENU**. . . **tArE** is displayed.
2. Press **MENU** repeatedly until **battErY** is displayed.
3. Press **SELECT**. . . Incoming battery voltage is displayed.
4. Press **SELECT**. . . **battErY** is displayed.
5. Press **G/N** to return to weighing mode.

Service Repairs

If you find the indicator or one or more of the Weigh Bars to be defective, contact your supplier, or send your equipment back to the factory for repair, postage prepaid.

Include the following information:

1. Your name and address
2. Supplier name and address
3. Date of purchase
4. **IMPORTANT:** An informal note describing symptoms of the problem.

Display Messages

HELLO	Indicator is being reinitialized. Message is displayed briefly at time of power-on.
----	Indicator is in state of over-capacity.
----	Indicator is in state of under-capacity.
Error	System is not functioning properly. Weight is not being calculated because scale weight is too high or too low. (Refer to information on “Indicator Lockup” in Troubleshooting section of manual.)
Print	Indicator is transmitting data. Appears after pressing the PRINT key when printing all memory channels.
CAn't	Displayed when attempting to M+ when a gross weight is negative or when motion is occurring.

Miscellaneous Information

Mounting the Model 915A

The Model 915A mounts on a quick-detach bracket. Weld or bolt the quick-detach bracket into place, as follows:

1. Choose a mounting location that is
 - convenient for operation of the indicator, and
 - protected from moving parts or from other moving machinery.
2. Hold the indicator at the proposed mounting location, and verify that the display is legible and the controls accessible.
3. Positioning the quick-detach bracket with the wider end at the top, mark the desired mounting location. If bolting, use the quick-detach bracket as a template and mark and drill holes.
4. Weld or bolt the quick-detach bracket at the appropriate location. If bolting, use double nuts or self-locking nuts to protect both indicator and machinery.
5. Insert the indicator bracket into the quick-detach bracket and push it down into place.
6. For mobile applications, wrap and twist a strong wire around the indicator bracket and the quick-detach bracket to stabilize the mounting.

RD 912 Remote Display

The RD912 is a remote display that is compatible with the Model 915A. (An RD912 output option is required on the Model 915A for interfacing.) The interface cable plugs directly into the bottom of the Model 915A (see Figure 4 below). When using the remote display, any data displayed on the Model 915A is also displayed on the RD912.

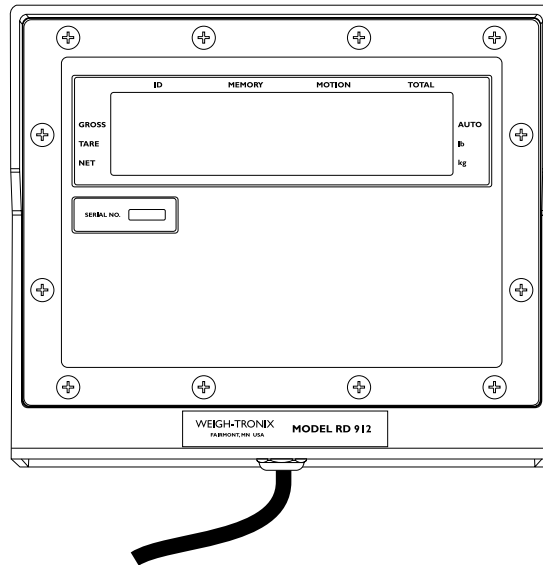

Figure 4
Model 912 Remote Display

Optional Radio Remote Transmitter (XM710-L) and Receiver

An optional radio remote transmitter and receiver can be installed

This option lets the user configure the XM710 to act as a **ZERO**, **PRINT**, **M+**, **M-**, **RM**, or **G/N** key and work at up to 100 feet away. It can be installed in either the Model 915A or the RD912.

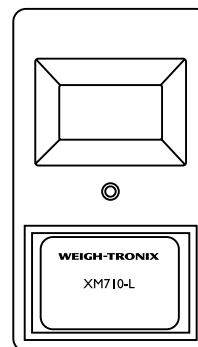

Figure 5
Radio Remote

Press the **MENU** key to scroll → in the menu.
 Press the **SELECT** key to move ⇅ in the menu

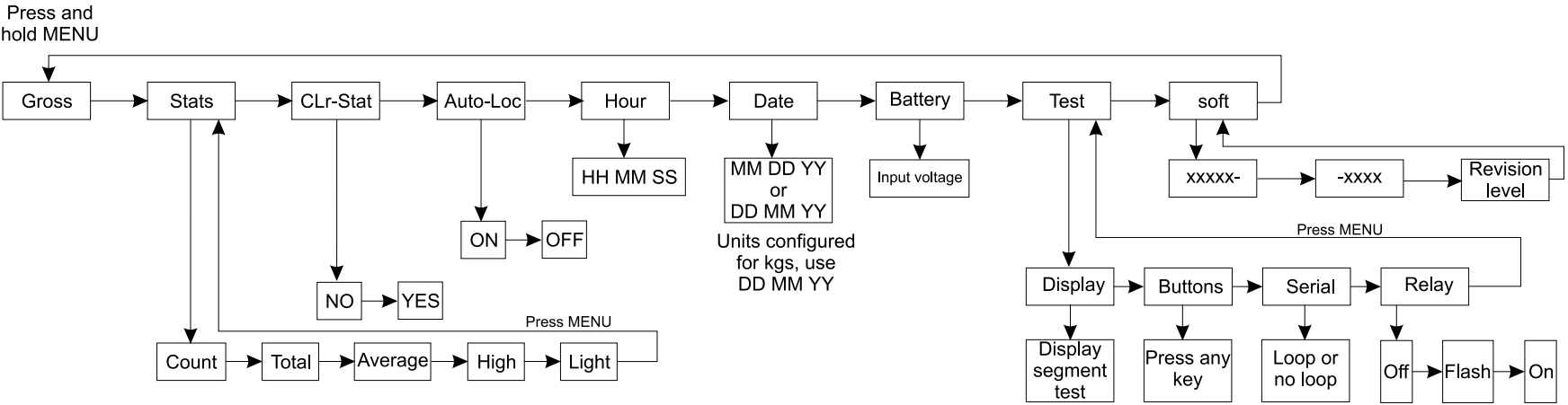

Figure 6
 User's Menu

Appendix A: Customizing Printouts

Layouts 1-5

The hidden E key is between the 9 and the M+ keys on the indicator

Below are the steps to choosing Layout 1-5.

1. Key in **915**. **915** is displayed.
2. Press hidden **E** key and hold for two seconds. **915A** is displayed.
3. Press **SELECT**. **ConF** is displayed.
4. Press **MENU** repeatedly until **SEriAl** is displayed.
5. Press **SELECT**. **bAUd** is displayed.
6. Press **MENU** repeatedly until **LAYoUt** is displayed.
7. Press **SELECT**. **1 - 5** is displayed.
8. Press **MENU** until the layout you want is displayed, then press **SELECT**. That layout is now active.
9. Press **MENU** to scroll to next desired option or **G/N** to exit.

ASCII

The hidden E key is between the 9 and the M+ keys on the indicator

The ASCII parameter lets you customize the first line of Layouts# 1, 2, and 4 only. You key in the ASCII code number for the character you want to print. You can use up to 40 characters in the line. The ASCII codes are shown in Table 1.

1. Key in **915**. **915** is displayed.
2. Press hidden **E** key and hold for two seconds. **915A** is displayed.
3. Press **SELECT**. **ConF** is displayed.
4. Press **MENU** repeatedly until **SEriAl** is displayed.
5. Press **SELECT**. **bAUd** is displayed.
6. Press **MENU** repeatedly until **ASCII** is displayed.
7. Press **SELECT**. **1 _** is displayed. The **1** refers to the first of the 40 characters you can insert.
8. Key in the control code from Table 6 and press **MENU**. **2 _** is displayed.

Following is an example of how to enter **Model 915A, <CR><LF>**:

Enter the following control codes.

Sequence #	Control Code #	Control Character
01	#77	M
02	#79	O
03	#68	D
04	#69	E
05	#76	L
06	#32	SPACE
07	#57	9
08	#49	1
09	#53	5
10	#65	A
11	#13	Carriage Return
12	#10	Line Feed

To edit an existing sequence, display the sequence number you want to change, key in the new ASCII code number and press **SELECT** to return to the **ASCII** display. Press the **G/N** key when you are done.

9. Repeat step 8 until all control codes are entered, and press **SELECT**. . .

ASCII is displayed.

10. Press **G/N** key to exit programming mode and return to the gross/net weighing mode.

To Delete All ASCII Characters

1. Access **Serial-ASCII** in the configuration menu. . .

ASCII is displayed.

2. Press the **ZERO/CLEAR** key. . .

ASCII blinks and all the control codes are cleared.

Enabling Auto-Print

With auto print enabled, the indicator automatically transmits standard printout when motion ceases.

1. Key in **915**.

915 is displayed.

2. Press hidden **E** key and hold for two seconds.

915 A is displayed.

3. Press **SELECT**.

ConF is displayed.

4. Press **MENU** repeatedly until **SEriAl** is displayed.

5. Press **SELECT**.

bAUD is displayed.

6. Press **MENU** until **Auto** is displayed.

7. Press **SELECT**.

8. Press **MENU** to display either **OFF** or **on**.

9. Press **SELECT**.

Depending on your choice, auto print is now either off or on.

10. Press **MENU** to scroll to next desired option or **G/N** to exit.

Table 1 ASCII Control Codes

Code #	Control Character	Code #	Control Character	Code #	Control Character	Code #	Control Character
0	NUL	33	!	66	B	99	c
1	SOH	34	"	67	C	100	d
2	STX	35	#	68	D	101	e
3	ETX	36	\$	69	E	102	f
4	EOT	37	%	70	F	103	g
5	ENQ	38	&	71	G	104	h
6	ACK	39	'	72	H	105	i
7	BEL	40	(73	I	106	j
8	BS	41)	74	J	107	k
9	HT	42	*	75	K	108	l
10	Line Feed	43	+	76	L	109	m
11	VT	44	,	77	M	110	n
12	Form Feed	45	_	78	N	111	o
13	Carriage Return	46	.	79	O	112	p
14	S0	47	/	80	P	113	q
15	S1	48	0	81	Q	114	r
16	DLE	49	1	82	R	115	s
17	DC1	50	2	83	S	116	t
18	DC2	51	3	84	T	117	u
19	DC3	52	4	85	U	118	v
20	DC4	53	5	86	V	119	w
21	NAK	54	6	87	W	120	x
22	SYN	55	7	88	X	121	y
23	ETB	56	8	89	Y	122	z
24	CAN	57	9	90	Z	123	{
25	EM	58	:	91	[124	
26	SUB	59	;	92	\	125	}
27	ESC	60	<	93]	126	~
28	FS	61	=	94	^	127	Delete
29	GS	62	>	95	-		
30	RS	63	?	96	`		
31	US	64	@	97	a		
32	Space	65	A	98	b		

This page left intentionally blank.

Weigh-Tronix

1000 Armstrong Dr.
Fairmont, MN 56031 USA
Telephone: 507-238-4461
Facsimile: 507-238-8283
e-mail: ag@weigh-tronix.com
www.agscales.com

WEIGH-TRONIX

Weighing Products & Systems